

Series JUMBO[®] S24 to S84

Solid handling submersible sludge pumps

- **Cost-effective pumping**
– compact design
with high efficiency
and low maintenance
requirements
- **Ease of doing business**
– portable pumps with
minimal accessory
requirement
- **Available for immediate
use**
- **Solid handling ability**
– wear resistant
vortex impeller and
pump casing
- **Floodproof**
– reliable product range
for cost-effective
solutions



JUMBO® S24 to S84 - Solid handling pumps with high quality in every detail

- **Robust hydraulic parts** for tough conditions combined with **light weight motor components** for easy handling.
- Effective **efficient modular system** of construction for low inventory costs and easy service.
- **Plug-in-start** for immediate installation using contactor unit and thermal sensors built in the motor.
- Reliable performance from **vortex impeller** handling up to 2" solids.

Motor housing and top cover in light weight aluminium.

Pump casing with DN flanged outlet - discharge elbow for portable use or ABS automatic coupling system.

Vortex impeller design with excellent solid-handling ability. Impellers interchangeable between pumps. Impeller trimming is possible for special applications.

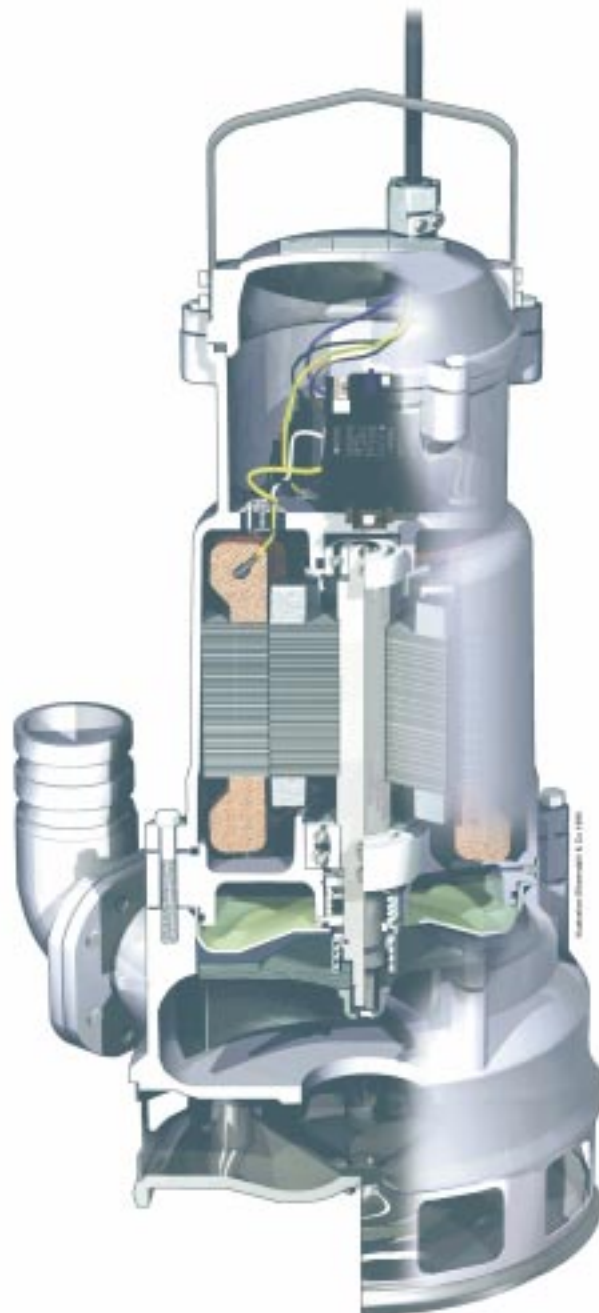



Built-in contactor with coil in series with thermal sensors.

Rigid stainless steel shaft supported on maintenance free ball bearings.

Two mechanical shaft seals are lubricated in environmentally friendly oil from the oil chamber. Upper seal has stainless against carbon. Lower seal has durable silicon carbide faces.

Impeller and pump casing of wear resistant ductile cast iron.

This picture shows JUMBO S84

Pump type	Motor power*		Speed rpm	Phase	Voltage, current** and (cable type***)			Weight kg	Discharge elbow		
	P ₁ kW	P ₂ kW			230V A	400V A	500V A				
JUMBO S24 W(KS)	2.1	1,5	2750	1	9,8 (1)			34	• 3"	□ 3"	□ 3"/B
JUMBO S24 D(KS)	2.4	2,0	2850	3	7,3 (2)	4,2 (2)	4,0 (2)	33	• 3"	□ 3"	□ 3"/B
JUMBO S44 D(KS)	3.9	3.3	2850	3	12 (3)	6,8 (3)	5,2 (3)	40	• 3"	□ 3"	□ 3"/B
JUMBO S54 D	6.2	5.2	2850	3	20 (3)	11 (3)	8,4 (3)	62	• 4"	□ 4"	□ 4"/A
JUMBO S84 D	9.4	8,0	2850	3	28 (4)	16 (3)	12,2 (3)	74	• 4"	□ 4"	□ 4"/A

*P₁ = Power taken from mains
P₂ = Power at motor shaft

**Overload relay setting for star delta, divide rated current by 1.73.

*** Cable Type:
(1) H07RN-F3x1,5mm²
(2) H07RN-F4x1,5mm²
(3) H07RN-F4x2,5mm²
(4) H07RN-F4x4mm²

Standard pump supplied with:

- 20m power cable with CEE plug
- Maximum impeller diameter ****
- Pump connected for DOL start
- Discharge outlet, hose

Options:

- Starter boxes
- KS version with built in float switch on JUMBO S24 & S44
- Minimum impeller diameter
- Pump connected for Star/Delta start (10x2,5mm²)
- Various sizes of outlets

**** Requires half motor submerged for continuous duty

- = Standard
- = Available as an option



JUMBO S24

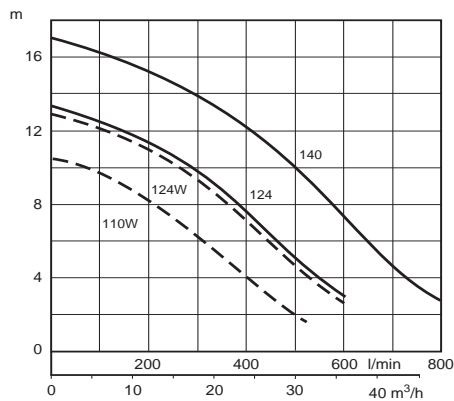

JUMBO S44

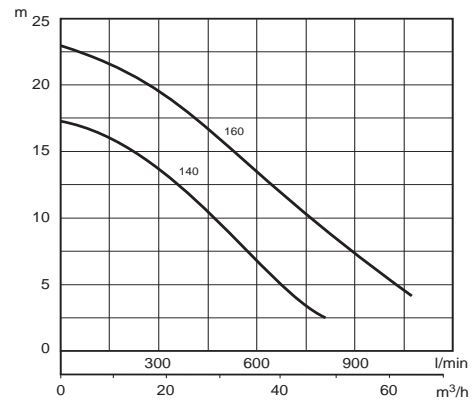

JUMBO S54

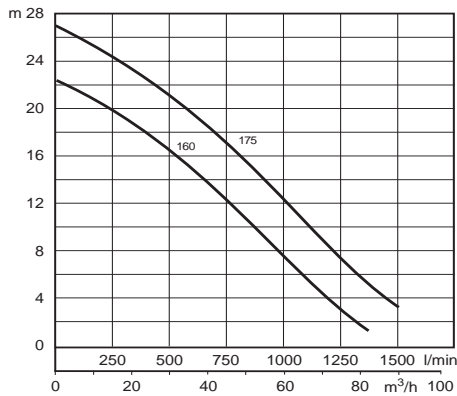

JUMBO S84

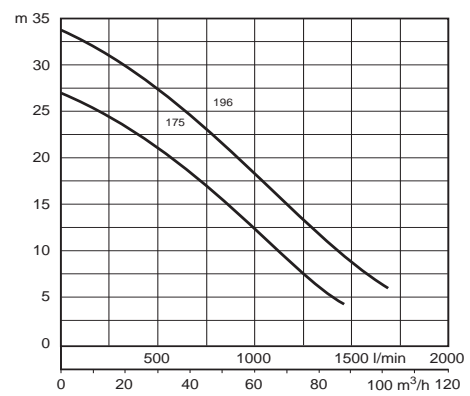

Dimensions (discharge see above)

mm

	A	B	C	D	E
JUMBO S24W	682	336	230	Ø 145	M16 - 4x
JUMBO S24D	682	336	230	Ø 145	M16 - 4x
JUMBO S44D	682	336	230	Ø 145	M16 - 4x
JUMBO S54D	766	442	289	Ø 160	M16 - 8x
JUMBO S84D	816	442	289	Ø 160	M16 - 8x

Standard discharge flange

JUMBO S24-S44 DN65
JUMBO S54-S84 DN80

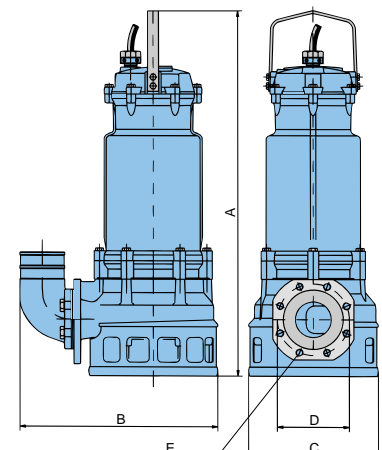



ABS
COST-EFFECTIVE PUMPING

ABS reserves the right to alter specifications due to technical developments

Austria

Tel. +43 2236 642 61
Fax +43 2236 642 66

Belgium

Tel. +32 2 725 79 00
Fax +32 2 725 71 19

Brazil

Tel. +55 41 348 1991
Fax +55 41 348 1879

Canada

Tel. +1 905 670 4677
Fax +1 905 670 3709

Denmark

Tel. +45 48 17 11 10
Fax +45 48 17 19 11

Estonia

Tel. +372 656 3398
Fax +372 656 3385

Finland

Tel. +358 9 506 88 90
Fax +358 9 55 80 53

France

Tel. +33 1 49 35 24 50
Fax +33 1 48 54 42 82

Germany

Tel. +49 2246 13 0
Fax +49 2246 13 200
Tel. +49 62 57 9317 0
Fax +49 62 57 9317 99

Great Britain

Tel. +44 1293 82 19 75
Fax +44 1293 82 19 76

Greece

Tel. +30 1 95 325 01/02/03
Fax +30 1 95 325 04

Hungary

Tel. +36 1 372 78 50
Fax +36 1 209 10 22

Ireland

Tel. +353 53 63 200
Fax +353 53 42 335

Italy

Tel. +39 051 89 00 911
Fax +39 051 86 18 48

Netherlands

Tel. +31 43 352 50 50
Fax +31 43 363 33 95

Norway

Tel. +47 67 554 700
Fax +47 67 554 750

Poland

Tel. +48 22 633 82 87
Fax +48 22 633 86 44

Singapore

Tel. +65 4633 933
Fax +65 4622 122

South Africa

Tel. +27 11 397 1612
Fax +27 11 397 1795

Spain

Tel. +34 91 670 28 51
Fax +34 91 666 58 68

Sweden

Tel. +46 31 706 16 00
Fax +46 31 27 29 20

Switzerland

Tel. +41 71 694 6555
Fax +41 71 694 6556

Turkey

Tel. +90 216 455 2256
Fax +90 216 455 2265

USA

Tel. +1 203 238 2700
Fax +1 203 238 0738

All other countries

ABS Pumps International
Head Office, Sweden
Tel. +46 31 83 63 00
Fax +46 31 18 49 06

Agents and distributors

ABS has sales and service representation in more than 100 countries the world over.

www.abspumps.com

ABS is a company in the Cardo Group